

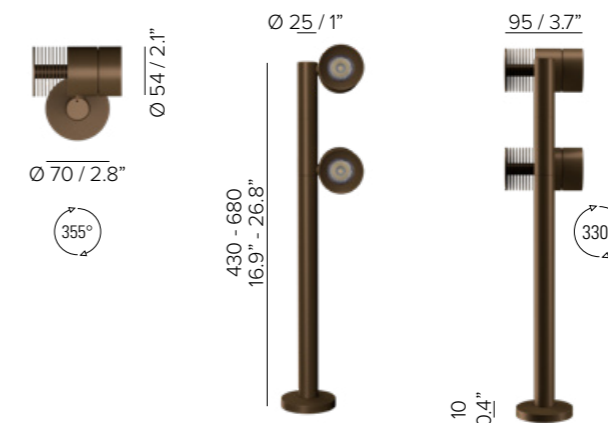

# MAIA ET

## SPECIFICATIONS

base code	672
typology	Two independent heads projector with recessed antiglare optics
mounting	On surface by fixing base or on ground using stainless steel AISI 304 spike (code 69855) to be separately ordered as accessory
stem height	430 mm - 680 mm / 16.9" - 26.8"
diameter	54 mm / 2.1"
length	95 mm / 3.7"
construction	Fixture: turning and milling aluminum. Stainless steel A2 screws. Lens: PMMA. Protective glass complete with silicone gasket
finishes	Powder coated
ingress protection	IP66. North America wet location. Built-in protection from water infiltration and moisture
lamp type	LED array on printed circuit board. Remote power supply not included
lamp wattage	12W (6W per head) at 48V DC and 500 mA. North America 12W (6W per head) at 24V DC and 10W (5W per head) at 350 mA
lamp lumens	630lm per head
delivered lumens	400lm (3000K CRI93, 36°) per head
lumen maintenance	50.000h L90
beam	16°, 36°, 45°. Two independent heads, adjustable 355° on the horizontal plane and 330° on the vertical plane
kelvin	2200K CRI80, 2200K CRI93, 2700K CRI93, 3000K CRI93 / 3 step MacAdam ellipse
special features	Unpolarized electronic system (24V DC: reverse polarity protection) - Safe wiring. Water drainage system - Water stop technology.
dimming options	48V DC, 24V DC: Thermal Sensor - Two wires dimming Push button, potentiometer, 0-10V, DALI, DMX, KNX. Dimming options depend on power supply and additional control units to be separately ordered as accessories
listings	CE, ETL listed for wet location



\* weight referred to the 430mm / 16.93" model

# MAIA ET

## ORDER CODE

BASE CODE	A1 . STEM HEIGHT	A . POWER SUPPLY	B . KELVIN	C . BEAM	D . FINISHES	E . OTHER
<b>672</b>	<b>14</b> 430 mm <b>15</b> 680 mm	<b>8</b> 48V DC power supply NOT included  <b>L</b> 500 mA power supply NOT included  <b>R</b> listed 24V DC power supply NOT included  <b>U</b> listed 350 mA power supply NOT included	<b>5</b> 3000K CRI93  <b>8</b> 2700K CRI93  <b>D</b> 2200K CRI93 (350/500 mA)  <b>I</b> 2200K CRI80 (24/48V DC)	<b>2</b> spot 16°  <b>4</b> flood 36°  <b>5</b> wide flood 45°	<b>F</b> golden bronze  <b>Q</b> anthracite RAL 7024	<b>A</b> hidden cable exit  <b>B</b> side cable exit

Example: BASE CODE **672** A1 **14** A **8** B **8** C **4** D **6** E **A** = **67214-8846A**



# MAIA ET

## ACCESSORIES

### REQUIRED ACCESSORIES - NOT INCLUDED

code	output power	input voltage / frequency	IP	dimensions mm
69180	30W	90-264V	47-63Hz IP20	L160xW46xH30
69185	40W	90-305V	47-63Hz IP67	L171xW62xH37
69186	60W	90-305V	47-63Hz IP67	L171xW62xH37
69187	100W	90-305V	47-63Hz IP67	L220xW68xH39
69195	75W	100-305V	47-63Hz IP67	L180xW63xH36
69196	100W	100-305V	47-63Hz IP67	L199xW63xH36
69096	55W	99-264V	50-60Hz IP20	L129xW76xH30
69088	ON/OFF, 20W / max 1	100-264V	50-60Hz IP20	L135xW38xH28
69091	1-10V, 20W / max 1	99-264V	50-60Hz IP20	L120xW52xH22
69080	DALI, 20W / max 1	220-240V	50-60Hz IP20	L120xW52xH22
69206	DALI, 24W / max 1	99-264V	50-60Hz IP67	L122xW54xH26

<sup>1</sup>for a perfect dimming, it is necessary that the power supply is saturated to 100%

Class 2 power supply  
24V DC  
350 mA

Consult **B LIGHT North America**  
Lighting Group Network  
T: 212.775.6363  
E: info@lightinggroupnetwork.com

code	description	dimensions mm
69842	IP68 connector, 1 IN - 1 OUT, 2 wires	W37xD22xH37
69847	IP68 connector, 1 IN - 2 OUT, parallel wiring, 2 wires	W45xD30xH17

### OPTIONAL ACCESSORIES

code	description	dimensions mm
69862	spike	W60xD30xH240
69876-6	half snoot for glare control - white RAL 9003	Ø56xH85
69876-A	half snoot for glare control - grey RAL 9006	Ø56xH85
69876-F	half snoot for glare control - golden bronze	Ø56xH85
69876-Q	half snoot for glare control - anthracite RAL 7024	Ø56xH85

### SPECIAL FEATURE: WATER DRAINAGE SYSTEM



When aimed upwards, the water is collected in the cup and is drained from the bezel cavities

